

# MERIDIAN<sup>®</sup>

## SEED TITAN™ 2XT BOX SEED TENDER



[meridianmfg.com/box-seed-tender](http://meridianmfg.com/box-seed-tender)



## OPERATOR'S MANUAL



# PRODUCT REGISTRATION FORM



**Attention Dealers:**

You can register products online through the Dealer Login: <http://dealers.meridianmfg.com/login/>

It is mandatory to register your product in order to qualify for future warranty claims that may arise. Knowingly falsifying information on this form will result in the voiding of the product warranty.

You may scan/photograph this completed form (must be legible), email it to: [register@meridianmfg.com](mailto:register@meridianmfg.com)  
A copy of this form may be mailed to Meridian Manufacturing Inc. 2902 Expansion Blvd. Storm Lake, IA 50588

Buyer's Name _____	Dealer's Name _____
Address _____	Address _____
City, State/Prov _____	City, State/Prov _____
Zip/Postal Code _____	Zip/Postal Code _____
Phone Number _____	Phone Number _____

**Note:** Registering a product in multiple entry format is only allowed when the product has the same model number and the same dealer, however each serial number must be legibly listed for each unit. Delivery dates for a multiple entry must be within a one month time frame.

Product Information \_\_\_\_\_

Model # _____	Serial # _____
Invoice Date _____	

**Important:** Please send this form to the Meridian Manufacturing Inc. location which built this product being registered. If you require further assistance call you're dealer or the Meridian outlet nearest to your location.

We want to thank you for purchasing a Meridian manufactured product. Whether this is your first Meridian purchase or you have been a customer for years, you are now part of the Meridian community of customers and we appreciate your business.

It is important that you now complete the product registration information and this form indicating you have received delivery. This registration and information is necessary to ensure you have access to warranty and product updates in the event it be required in the future.

Registration can be completed by using this form or visiting your dealer who will complete the form online. You will be given access to the Meridian Community and become eligible for updates, special offers and prizes.

Again, thank you for choosing Meridian.

I have thoroughly instructed the buyer on the above described equipment. The review included the content of this manual, equipment care, adjustments, safe operation and warranty policy.

Date \_\_\_\_\_ Dealer's Signature \_\_\_\_\_

The above equipment and this manual have been received by me. I have been thoroughly instructed as to care, adjustments, safe operation and applicable warranty policy.

Date \_\_\_\_\_ Buyer's Signature \_\_\_\_\_

## DEALER INSPECTION REPORT



MERIDIAN MANUFACTURING INC.  
2902 EXPANSION BLVD. STORM LAKE, IA 50588  
T: (800) 437-2334 P: (712) 732-1780 F: (712) 732-1028  
www.meridianmfg.com iowa\_warranty@meridianmfg.com

Unit's Model Number \_\_\_\_\_

Unit's Serial Number \_\_\_\_\_

- Tender frame secured to trailer
- Check fuel level and gas shut-off
- Check engine oil level
- Check reduction case oil level
- Start Honda engine
- Brake and lighting harness connection
- Remote throttle control functions
- Lubricate unit where necessary
- Check air pressure in tires
- Electric brakes in working condition
- All guards/shields installed correctly
- All safety signs installed and intact
- Reflectors and lights clean and working
- Review safety and operating instructions
- Inspect customer's hitch for 2-5/16" ball/gooseneck hitch
- Verify receipt of all options ordered

# CERTIFICATE OF ORIGIN



MERIDIAN MANUFACTURING INC.  
2902 EXPANSION BLVD. STORM LAKE, IA 50588  
T: (800) 437-2334 P: (712) 732-1780 F: (712) 732-1028  
www.meridianmfg.com iowa\_warranty@meridianmfg.com

LICENSING INFORMATION	Delivery Date _____
DEALER _____	SOLD TO _____
Address _____	Address _____
City _____	City _____
State _____	State _____
Zip Code _____	Zip Code _____
Phone Number _____	Phone Number _____
Unit's Model Number _____	Unit's Serial Number _____

This page intentionally left blank

# TABLE OF CONTENTS

<b>DESCRIPTION</b>	<b>PAGE</b>
Section 1: INTRODUCTION . . . . .	1-1
Section 2: SAFETY . . . . .	2-1
2.1 Safety Orientation . . . . .	2-2
2.2 General Safety . . . . .	2-2
2.3 Equipment Safety Guidelines . . . . .	2-3
2.4 Safety Decals . . . . .	2-3
2.4.1 Applying Decals . . . . .	2-3
2.5 Safety Decal Location . . . . .	2-4
2.6 Work Preparation . . . . .	2-6
2.7 Placement Safety . . . . .	2-6
2.8 Lock-Out Tag-Out Safety . . . . .	2-6
2.9 Maintenance Safety . . . . .	2-7
2.10 Tire Safety . . . . .	2-7
2.11 Battery Safety . . . . .	2-7
2.12 Engine Safety . . . . .	2-8
2.13 Operating Safety . . . . .	2-9
2.14 Hydraulic Safety . . . . .	2-9
2.15 Transport Safety . . . . .	2-10
2.16 Storage Safety . . . . .	2-10
Section 3: OPERATION . . . . .	3-1
3.1 Machine Components . . . . .	3-2
3.2 Components and Controls . . . . .	3-3
3.3 Machine Break-In . . . . .	3-8
3.3.1 Before Starting . . . . .	3-8
3.3.2 Inspections at 1/2, 5, and 10 Hours . . . . .	3-8
3.4 Pre-Operation Checklist . . . . .	3-8
3.5 Attaching to Tow Vehicle . . . . .	3-10
3.6 Loading Seed Boxes . . . . .	3-12
3.7 Delivering Seed to Planter . . . . .	3-14
3.8 Unplugging . . . . .	3-17
3.9 Storage . . . . .	3-18
3.9.1 Placing into Storage . . . . .	3-18
3.9.2 Removing from Storage . . . . .	3-18

continued on next page

## TABLE OF CONTENTS

<b>DESCRIPTION</b>	<b>PAGE</b>
Section 4: SERVICE AND MAINTENANCE . . . . .	4-1
4.1 Fluids and Lubricants. . . . .	4-1
4.1.1 Greasing. . . . .	4-2
4.2 Servicing Intervals . . . . .	4-3
4.2.1 After 10 Hours or Daily. . . . .	4-3
4.2.2 After 50 Hours or Weekly . . . . .	4-3
4.2.3 After 100 Hours or Monthly . . . . .	4-3
4.2.4 After 200 Hours or Annually. . . . .	4-4
4.3 Maintenance Procedures. . . . .	4-5
4.3.1 Tires . . . . .	4-5
4.3.2 Wheel Bearings . . . . .	4-5
4.3.3 Tube Fold-Over Hinge . . . . .	4-5
4.3.4 Welding Repairs. . . . .	4-5
4.3.5 Battery . . . . .	4-5
4.3.6 Engine . . . . .	4-6
4.3.7 Engine Speed Setting . . . . .	4-7
4.3.8 Change Hydraulic Oil . . . . .	4-8
4.3.9 Change Hydraulic Oil Filter . . . . .	4-8
4.3.10 Unplugging Auger Tube . . . . .	4-9
4.3.11 Trailer Break-Away System . . . . .	4-10
4.3.12 Wheel Bolt Torque Requirements. . . . .	4-11
4.3.13 Axle Bolts and Frame Hold-Down Bolts . . . . .	4-11
4.4 Service Record. . . . .	4-13
4.5 Ordering Parts . . . . .	4-14
Section 5: TROUBLESHOOTING. . . . .	5-1
Section 6: REFERENCE. . . . .	6-1
6.1 Specifications. . . . .	6-1
6.2 Bolt Torque. . . . .	6-2
Warranty Statement	

## Section 1: INTRODUCTION

Thank you for choosing a Meridian® Box Seed Tender. The equipment we design and manufacture to meet the exacting standards of the agricultural industry.

Keep this manual for future reference. Call your dealer, distributor or Meridian if you need assistance, information, additional/replacement copies or a digital copy of this document.

The information provided herein is of a descriptive nature. Meridian Manufacturing Inc. reserves the right to modify the machinery design and specifications provided herein without and preliminary notice.

Performance quality may depend on the material being handled, weather conditions and other factors.

### OPERATOR ORIENTATION

The directions left, right, front, and rear, as mentioned throughout this manual, are as seen from the tow vehicle driver's seat, facing in the direction of travel.

### SERIAL NUMBER

Always give your dealer the serial number of your tender when ordering parts or requesting service or other information.

Use the space provided for easy reference.

Trailer VIN Plate #: \_\_\_\_\_

Tender Model #: \_\_\_\_\_

Tender Serial #: \_\_\_\_\_

Engine Model #: \_\_\_\_\_

Engine Serial #: \_\_\_\_\_



Fig 1 - Serial number located at front driver-side corner

## PATENT INFORMATION



Meridian Manufacturing Inc. continuously enhances its product offering through product improvements and new product innovations. Marketplace feedback, technological innovation, new materials and manufacturing methods, and a philosophy of continuous improvement constantly challenge the company to develop new and better ways of addressing market needs. Meridian is committed to innovation and reinvestment and as a result, the company maintains a portfolio of patents and intellectual property. For more information on our patents, see the website:

[www.meridianmfg.com/patents](http://www.meridianmfg.com/patents)

## Section 2: SAFETY

3 Big Reasons why safety is important to you:

- Accidents Disable and Kill
- Accidents Cost
- Accidents Can Be Avoided

The Safety Alert Symbol means:



The Safety Alert Symbol identifies important safety messages on the seed tender and in this manual.

The following signal words are used in this manual to express the degree of hazard for areas of personal safety.

When you see the symbol and/or the signal words described below, obey the accompanying message to avoid possible injury or death.



Indicates a hazardous situation that, if not avoided, will result in death or serious injury. This signal word is limited to the most extreme situations. Typically for machine components which, for functional purposes, cannot be guarded.



Indicates a hazardous situation, if not avoided, could result in death or serious injury. This word identifies hazards that are exposed when guards are removed. It may be used to alert against unsafe practices.



Indicates a hazardous situation, if not avoided, could result in minor or moderate injury. It may be used to alert against unsafe practices.



Indicates practices or situations which may result in the malfunction of, or damage to equipment.



Safety instructions (or equivalent) signs indicate specific safety-related instructions or procedures.

## 2.1 SAFETY ORIENTATION

YOU are responsible for the SAFE operation and maintenance of your Meridian® Seed Tender. Be sure that everyone who will operate, maintain or work around it, is familiar with the safety, operating and maintenance procedures.











This manual will take you step-by-step through your working day. It will alert you to all the safe practices that should be adhered to while operating the tender.

Remember, you are the key to safety. Good safety practices not only protect you but also the people around you. Make these practices a regular part of your safety program. Be certain that everyone who will work with this equipment follows these procedures.

Most accidents can be prevented. Do not risk injury or death by ignoring good safety practices.

- Tender owners must give operating instructions to operators or employees before allowing them to operate the machine.
  - Procedures must be reviewed annually thereafter, as per OSHA (Occupational Safety and Health Administration) regulation 1928.57.
  - The operator must be responsible, properly trained and physically able. They should be familiar with farm machinery in general.
- Think SAFETY! Work SAFELY!

## 2.2 GENERAL SAFETY

- Read and understand the Operator's Manual and all safety decals before operating, maintaining, adjusting or unplugging the tender. 
- Only trained, competent persons shall operate the unit. An untrained operator is not qualified to operate the machine.
- Have a first-aid kit available for use should the need arise. 
- Provide a fire extinguisher for use in case of an accident. Store in a highly visible place. 
- Do not allow riders.
- Do not allow children, spectators or bystanders within hazard area around the machine.
- Wear appropriate protective equipment (PPE). This list may include but is not limited to:
  - Hard hat 
  - Protective shoes with slip resistant soles 
  - Eye protection 
  - Work gloves 
  - Hearing protection 
  - Respirator or filter mask 
  - Hi-Visibility safety vest 
- Never use alcoholic beverages or drugs which can hinder alertness or coordination while operating this equipment.
  - Consult your doctor about operating this machine while taking prescription medications.
- If the elderly are assisting with farm work, their physical limitations need to be recognized and accommodated.
- Do not allow long hair, loose fitting clothing or jewelry to be around equipment.

## 2.3 EQUIPMENT SAFETY GUIDELINES

- Safety of the operator and bystanders is one of the main concerns when designing and developing this tender. However, every year many accidents occur which could have been avoided by a few seconds of thought, and a more careful approach to handling equipment.
- Do not allow personnel to operate this unit until they have been trained. They must know all safety precautions.
- In order to provide a better view, certain images in this manual may show an assembly with safety guards removed.
  - Equipment should never be operated in this condition.
  - All guards must be in place.
  - If removal becomes necessary for repairs, replace the guard prior to use.
- This equipment is dangerous to children and persons unfamiliar with its operation.
  - The operator must be responsible, properly trained and physically able. You should be familiar with farm machinery in general.
- Never exceed the limits of a piece of machinery. If its ability to do a job, or to do so safely, is in question - DO NOT TRY IT.
- Do not modify the equipment in any way. Unauthorized modification result in serious injury or death and may impair the function and life of the equipment.
- The design and configuration of this tender includes safety decals and equipment.
  - They need to be clean, readable and in good condition.

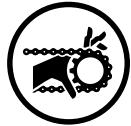

## 2.4 SAFETY DECALS

- Keep safety decals clean and legible at all times.
- Replace safety decals that are missing or have become illegible.
- Replaced parts must display the same decal(s) as the original parts.
- All safety decals have a part number in the lower right hand corner. Use this part number when ordering replacements.
- Decals are available from your authorized distributor, dealer's parts department or from Meridian Manufacturing Inc.

### 2.4.1 Applying Decals:

1. Be sure the application area is clean and dry. Ensure the surrounding temperature is above 10°C (50°F).
  - a. Remove all dirt, grease, wax from surface.
  - b. Clean the area with a non-ammonia based cleaner.
  - c. Wipe the clean surface with isopropyl alcohol on paper towel, and allow to dry.
2. Determine the exact position before you remove the backing paper.
3. Peel a small portion of the split backing paper.
4. Align the decal over the specified area. Use a squeegee to carefully press the small portion, with the exposed adhesive backing, into place.
5. Slowly peel back the remaining paper and carefully smooth the rest of the decal into place.
6. Small air pockets can be pierced with a pin and smoothed out using the squeegee, or a piece of sign backing paper.

## 2.5 DECAL LOCATION

The following illustrations show the general location of decals on this tender.

- The position of decals may vary depending on the machine's options.
- Decals are not shown at actual size.

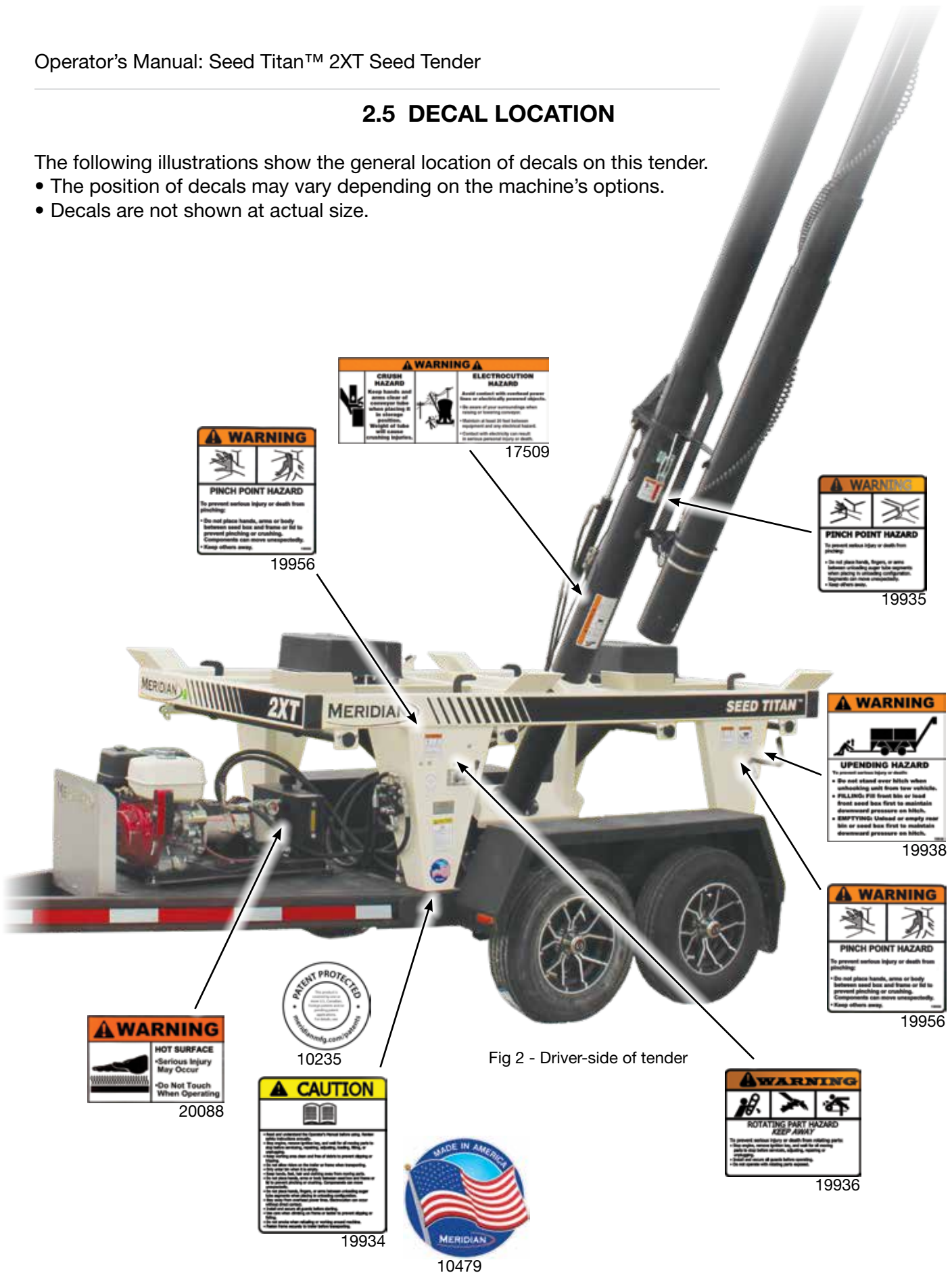

Fig 2 - Driver-side of tender



Fig 3 - Passenger-side of tender

**WARNING**

**UPENDING HAZARD**

To prevent serious injury or death:

- Do not exceed over height when unhooking with from base vehicle.
- FILLING: Fill front bin or load front seed base first to maintain downstroke pressure on hitch.
- EMPTYING: Unload or empty rear bin or seed base first to maintain downstroke pressure on hitch.

19938

**WARNING**

**PINCH POINT HAZARD**

To prevent serious injury or death from pinching:

- Do not place hands, arms or body between seed base and frame or fit to prevent pinching or crushing. Components can move unexpectedly.
- Keep others away.

19956

**WARNING**

**ROTATING PART HAZARD**

**KEEP AWAY**

To prevent serious injury or death from rotating parts:

- Stop engine, remove ignition key, and wait for all moving parts to stop before servicing, cleaning, repairing or adjusting.
- Do not touch all guards before operating.
- Do not operate with rotating parts removed.

19936

Between hopper chutes,  
at the base of the auger

**REMEMBER** - If safety decals have been damaged, removed, become illegible, or parts were replaced without signage, new ones must be applied. New decals are available from your authorized dealer.

## 2.6 WORK PREPARATION

- Never operate the tender and its engine until you have read this manual, and understand the information.
  - Also, read the engine operator's manual.
- Be familiar with the safety messages found on the decals around this unit.
- Personal protective equipment (PPE) include:
  - Hard hat
  - Eye protection
  - Protective shoes
  - Work gloves



They are recommended during installation, placement, operation, maintenance and removal of the equipment.

- Do not allow long hair, loose fitting clothing or jewelry to be around equipment.
- **PROLONGED EXPOSURE TO LOUD NOISE MAY CAUSE PERMANENT HEARING LOSS!**

Agricultural equipment can often be noisy enough to cause permanent, partial hearing loss. We recommend that you wear hearing protection on a full-time basis if the noise in the Operator's position exceeds 80 db.



Noise over 85 db on a long-term basis can cause severe hearing loss.

Noise over 90 db adjacent to the operator over a long-term basis may cause permanent, total hearing loss.

### Note:

Hearing loss from loud noise (tractors, chain saws, radios, etc.) is cumulative over a lifetime without hope of natural recovery.

- Clear working area of stones, branches or hidden obstacles that might be hooked or snagged, causing injury or damage.
- Operate only in daylight or good artificial light.
- Be sure machine is in a stable position, is adjusted and in good operating condition.
- Ensure that all safety guards and safety decals are properly installed and in good condition.
- Before starting, inspect the unit for any loose bolts, worn parts, cracks, leaks or frayed belts. Make the necessary repairs.

Always follow the maintenance instructions.

## 2.7 PLACEMENT SAFETY

- Never move by hand.
- Locate tender providing enough space for trucks to load or unload.
- Operate tender on level ground, free of debris.

## 2.8 LOCK-OUT TAG-OUT SAFETY

- Establish a formal Lock-Out Tag-Out program for your operation.
- Train all operators and service personnel before allowing them to work around the area.
- Provide tags on the machine and a sign-up sheet to record tag out details.

## 2.9 MAINTENANCE SAFETY

- Review Section 4: Service and Maintenance, before maintaining or operating the tender.
- Follow good shop practices:
  - Keep service area clean and dry.
  - Be sure electrical outlets and tools are properly grounded.
  - Use adequate light for the job.
- Place all controls in neutral or off. Stop engine, and remove ignition key. Wait for all moving parts to stop before servicing, adjusting, repairing.
- Keep hands, feet, hair, and clothing away from all moving/rotating parts.
- Replace parts with genuine factory replacements parts to restore your equipment to original specifications.
  - Meridian Manufacturing Inc. will not be responsible for injuries or damages caused by using unapproved parts and/or accessories.
- Make sure there is plenty of ventilation.
  - Never operate engine in a closed building.
  - Exhaust fumes may cause asphyxiation.
- Clear the area of bystanders, especially children, when carrying out any maintenance and repairs or making any adjustments.
- Place stands or blocks under the frame before working beneath the machine.
- Before resuming work, install and secure all guards when maintenance work is completed.
- Replace damaged or not clearly visible decals.



## 2.10 TIRE SAFETY

- Failure to follow procedure when mounting a tire on a wheel or rim can produce an explosion and may result in serious injury or death.
- Do not attempt to mount a tire unless you have proper equipment and training to do the job.
- Have a qualified tire dealer or repair service perform required tire maintenance.
- When replacing worn tires, make sure they meet original tire specifications. Never undersize.
- Reference the tire side wall for information on the maximum cold tire pressure (PSI). Keep the tires inflated to this setting.





## 2.11 BATTERY SAFETY

- Keep all sparks and flames away from battery, as the gas given off by electrolyte is explosive.
- Avoid contact with battery electrolyte. Wash off any spilled electrolyte immediately.
- Wear safety glasses when working near batteries.
- Do not tip batteries more than 45 degrees, to avoid electrolyte loss.
- To avoid injury from spark or short circuit, disconnect battery ground cable before servicing any part of electrical system.
- When storing tender for an extended period:
  - Remove the battery.
  - Be sure it is fully charged.
  - Store it inside.
  - Do not sit battery on a cold, concrete floor.
- Before using the battery, after it has been in storage, be sure it is charged.



## 2.12 ENGINE SAFETY

- Read and understand the operating manual provided with the engine. 
- Use proper tools to service engine.
- Do not run engine in an enclosed area. Exhaust gases contain carbon monoxide, an odorless and deadly poison.
- Store fuel in approved safety containers.
- Do not store fuel near open flame.
  - Appliances such as a stove, furnace, or water heater use a pilot light which can create sparks.
- No smoking when filling fuel tank. 
- Do not remove fuel cap while engine is running.
- Do not refuel indoors where area is not well ventilated. Outdoor refueling is preferred.
- Do not refuel while engine is running. Allow engine to cool for 5 mins before proceeding.
- Use fresh fuel. Stale fuel can gum carburetor and cause leakage.
- Check fuel lines and fittings frequently for cracks or leaks. Replace if necessary.
- Do not operate engine if fuel has spilled. Move machine away. Avoid creating any ignition until the fuel has evaporated.
- Do not run engine above rated speeds. This may result in damage and injury.
- Do not tamper with the engine speed selected by the original equipment manufacturer.
- Do not operate engine with grass, leaves, dirt or other combustible materials in muffler area.
- Do not operate engine without muffler

- Do not tamper with governor springs, governor links or other parts which may increase the governed engine speed.
- Do not strike flywheel with hard object or metal tool. This may cause it to shatter in operation.
- Keep cylinder fins/governor parts free of grass and other debris which can affect engine speed.

### **WARNING**

#### HOT EQUIPMENT HAZARD

Do not touch muffler, cylinder or fins while engine is running. Contact will cause burns.

- Do not use this engine on any forest covered, brush covered, or grass covered unimproved land, unless a spark arrester is installed on muffler. The arrester must be maintained in effective working order by operator.

In the State of California the above is required by law (Section 4442 of the California Public Resources Code). Other states may have similar laws. Federal laws apply on federal land.



- Inspect the muffler periodically. Replace it when necessary.
  - If engine is equipped with a muffler deflector, inspect periodically. Replace with correct part.
- Do not check for spark, or crank engine with spark plug or spark plug wire removed.
- Do not run engine with air filter or its cover removed.

### **NOTICE**

#### POSSIBLE ENGINE DAMAGE

Decelerate engine slowly to stop. Avoid choking the carburetor to stop engine. Choke only for an emergency stop.

## 2.13 OPERATING SAFETY

- Anyone who will be operating this tender, or working around it, must read this manual. They must know operating, maintenance, safety info.
  - Review the manual annually.
- Clean or replace all safety decals if they cannot be clearly read and understood.
- Place all controls in neutral, and stop the engine. Remove the ignition key. Wait for all moving parts to stop before adjusting, repairing or unplugging.
- Keep all bystanders, especially children, away from the machine when running.
  - Also, when authorized personnel are carrying out maintenance work.
- Establish a Lock-Out, Tag-Out policy for the work site. Be sure all personnel are trained in and follow all procedures.
  - Lock-Out, Tag Out all power sources before servicing the unit or working around equipment.
- Be familiar with machine hazard area. If anyone enters hazard areas, shut down machine immediately. Clear the area before restarting.
- Keep hands, feet, hair and clothing away from all moving/rotating parts.
 
- Do not allow riders on the tender when moving or transporting it.
- Keep working area clean and free of debris to prevent slipping/tripping.
 
- Stay away from overhead obstructions and power lines during operation and transporting.
  - Electrocution can occur without direct contact.

- Do not operate the tender when any guards are removed.
- Chock wheels of tender before starting.
- Be sure that auger tube is empty before raising or lowering.

## 2.14 HYDRAULIC SAFETY

- Always place hydraulic controls in neutral. Then relieve pressure in hydraulic system before maintaining or working on machine.
- Be sure that all components in the hydraulic system are kept in good condition and are clean.
- Replace any worn, cut, abraded, flattened or crimped hoses.
- Do not attempt any makeshift repairs to the hydraulic fittings or hoses by using tape, clamps or cements. The hydraulic system operates under extremely high-pressure. Such repairs will fail suddenly and create a hazardous and unsafe condition.
- Wear proper hand and eye protection when searching for a high-pressure hydraulic leak. Use a piece of wood or cardboard as backstop instead of hand to isolate/identify a leak.
 
- If injured by a concentrated high-pressure stream of hydraulic fluid, seek medical attention immediately. Serious infection or toxic reaction can develop from hydraulic fluid piercing the skin surface.
 

## 2.15 TRANSPORT SAFETY

- Check that all the lights, reflectors and other lighting requirements are installed and in good working condition.
- Never allow riders on the tender.
- Comply with all local laws governing safety and transporting of equipment on public roads.
- Do not exceed a safe travel speed. Slow down for rough terrain and when cornering.
- Plan your route to avoid heavy traffic.
- Do not drink and drive.
- Be a safe and courteous driver.
  - Always yield to oncoming traffic in all situations, including narrow bridges, intersections, etc.
  - Watch for traffic when operating near or crossing roadways.



## 2.16 STORAGE SAFETY

- Store in an area away from human activity.
- If required, make sure the unit is solidly blocked up.
- Remove the battery and store a in dry location.
  - Do not sit it on a cold concrete floor.
- Make certain all mechanical locks are safely and positively connected before storing.
- Do not permit children to play on or around the stored machine.

## Section 3: OPERATION

### **WARNING**

- Read and understand the Operator's Manual.
- Before servicing, repairing or unplugging; stop engine, remove ignition key and wait for moving parts to stop.
- Clear the area of bystanders, especially children, before starting.
- Do not allow riders on the tender.
- Keep hands, feet, hair and clothing away from all moving and/or rotating parts.
- Be familiar with the hazard area. If anyone unauthorized enters, shut down the machine immediately. Clear area before restarting.
- Do not operate unit with guards removed.
- Keep working area clean and free of debris to prevent slipping or tripping.
- Create Lock-Out, Tag-Out policy for work site.
  - Ensure personnel follow all procedures.
  - Lock-out tag-out all power sources before servicing or working around equipment.

The Meridian® Seed Titan™ 2XT Seed Tender is designed to transport large amounts of seed to a planter or drill. Many features incorporated into this machine are the result of suggestions made by customers like you.

Hazard controls and accident prevention are dependent upon the personnel operating and maintaining it. Their awareness, concern, prudence and proper training are crucial.

It is the responsibility of the owner and operators to read this manual and to train all personnel before they start working with the machine. By following the recommended procedure, a safe working environment is provided for the operator, co-workers and bystanders in the area around the work site.

By following the operating instructions, in conjunction with a good maintenance program, your tender will provide many years of trouble free service.

### 3.1 MACHINE COMPONENTS

Large bulk seed boxes are loaded onto the seed tender frame. Slide gates control the flow of seed into the center-mounted auger hopper, which transfers it from the seed boxes into a planter or drill.

A gas engine mounted on the front of the trailer powers the hydraulic pump. The pump powers the auger drive motor and tube lift cylinder.

The auger unloads to the left side. A telescoping delivery spout on the end of the auger tube allows for convenient distribution.

Refer to the engine manual for specific information on it.

The main components, and their general location are listed below:

- a. Trailer Jack
- b. Hitch and Safety Chains
- c. Break-Away Trailer Brake System
- d. Gas Engine
- e. 12 Volt Battery
- f. Hydraulic Oil Reservoir and Filter
- g. Auger On/Off Switch
- h. Hydraulic Valve
- i. Hydraulic Oil Flow Control Valve
- j. Hoppers
- k. Box Lock-Down Bar with Handle (1 of 4)
- l. Lower Auger Tube
- m. Tube Locking Over-Center Latch Clamp
- n. Upper Auger Tube
- o. Delivery Spout
- p. Document Holder (inside rear right-side leg)

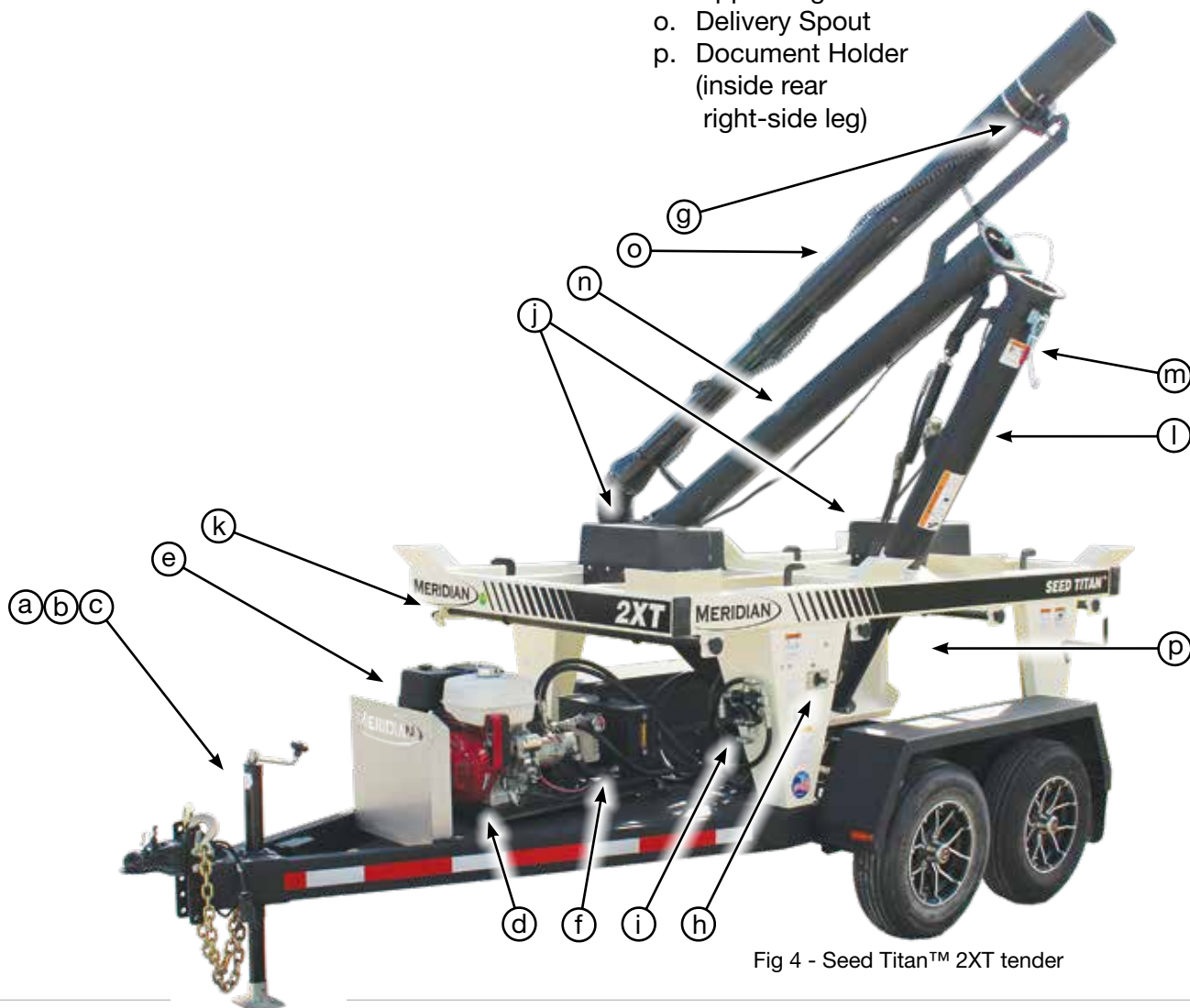

Fig 4 - Seed Titan™ 2XT tender

## 3.2 COMPONENTS AND CONTROLS

Before starting to work, all operators should familiarize themselves with the location and function of the components and controls.

The engine, tender options and their locations may vary.

### Gas Engine:

Read the engine manufacturer's manual for more detailed instructions.

- a. Ignition Switch:  
Insert the key to operate.
- b. Starting Rope:  
The retracting rope with T-bar is a manual method of starting the engine.
- c. Choke Lever:  
Choke the valve for starting when the engine is cold. Open the choke as the engine warms.



Fig 5 - Gas engine controls

### IMPORTANT:

Always run at maximum engine speed.

- d. Fuel Shut-Off Valve:  
Slide the fuel valve toward the engine to turn ON. Turn the valve OFF when not in use or before transporting.



Fig 6 - Gas engine, hyd pump and oil reservoir

### Hydraulic Pump:

The engine powers the hydraulic pump which generates flow to run all the hydraulic functions.

### Hydraulic Oil Reservoir:

The capacity of the reservoir is 3 US gallons (11.4 Liters).

**Hydraulic Oil Flow Control Valve:**

This valve regulates the flow of hydraulic oil to the motor. It can be used to control the speed of the auger.

To adjust the speed, loosen the knob, then move the lever in the desired direction.

- Move lever toward zero (0) for a slower speed.
  - Move toward ten (10) for a higher speed.
- Tighten the knob to hold the lever in place.



Fig 7 - Flow control valve

**IMPORTANT:**

This is the speed settings for best performance, further adjustment may be necessary depending on product type and condition:

- Set flow control valve to between 6 - 7.
- Engine at full throttle.



Fig 8 - Hydraulic valve

**Hydraulic Valve:**

This valve controls the hydraulic cylinder which folds the auger tube.

**Hydraulic Motor for Auger:**

The hydraulic motor is at the base of the auger, between the hopper chutes.



Fig 9 - Hydraulic auger motor and auger clean-out access

**⚠ WARNING**  
**ENTANGLEMENT HAZARD**  
 Do not place hands or fingers near rotating or moving parts.

- There are access doors at the top and bottom, between the chutes, for efficient clean-out.
- DO NOT OPEN WHILE AUGER IS RUNNING.



Fig 10 - Bottom clean-out access

**Battery (12 Volt):**

A 12 Volt battery supplies power to start the gasoline engine. The battery must be periodically recharged from an external source to keep it fully charged.

**Note:**

Engine does not recharge battery; manually recharge battery periodically.



Fig 11 - Battery

**Auger Tube:**

The auger tube unloads to the left-side. A hydraulic cylinder assists to unfold the upper tube into place.

**⚠ DANGER**  
 ELECTROCUTION HAZARD  
 Avoid contact with overhead power lines or electrically powered objects



Fig 12 - Auger tube folded for transport and storage

The telescoping delivery spout on the end of the auger tube enables a wide reach for convenient distribution.

The Auger On/Off Switch is fastened to the end of the spout, to control the auger when unloading.

**Tube Locking Over-Center Latch Clamp:**

Once the upper tube is raised and sitting in place, use the manual clamp to lock the upper and lower sections together.



Fig 13 - Auger tube in place, ready for operation

**Auger On/Off Switch:**

This toggle switch controls the auger motor.

**Note:**

The switch and wiring harness can be moved to more convenient location.

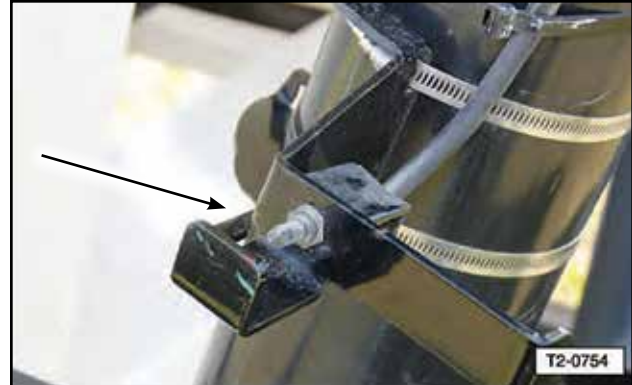

Fig 14 - Throttle switch

**Tender Hoppers:**

There are two hoppers, fitted with rubber boots. In this manual we identify their positions as:

- Seed Box 1 sits closest to the hitch.
- Seed Box 2 sits at the rear.

**Box Lock Latches:**

There are manual handles on the right-side of the tender which pivot to turn the latches, locking the box in place.



Fig 15 - Tender hopper and latches

Insert the snap pins to lock the handles.

**Hopper Lids:**

These lids cover the hoppers when the tender is not in use. When the lids are not needed, store them upsidedown along the center of the tender.



Fig 16 - Hopper lid in place

Use the snap pins to keep them secure.



Fig 17 - Hopper lid, shown in storage

**Trailer:**

The tender is mounted on a custom built trailer, which comes with a jack, safety chains and a Break-Away braking system.



Fig 18 - Trailer

**Break-Away System:**

A Break-Away System is installed on all trailers.

The control box contains LEDs to show the condition of enclosed battery. There is a Test button to check the battery level.



Fig 19 - Break-Away location

**IMPORTANT:**

Test the Break-Away Switch periodically. Remove the pin, then pull the trailer to feel if the brakes have engaged.

The cable attached to the Break-Away Switch pin, must go around the ball before coupling the trailer to the tow vehicle.

During transportation, if the trailer should detach from the transport vehicle, the pin will be pulled out engaging the trailer's brakes.



Fig 20 - Break-Away control box

**NOTICE**

**TRANSPORT HAZARD**  
Always secure the safety chains to the tow vehicle, in addition to the Break-Away Switch.



Fig 21 - Test Break-Away pin

### **3.3 MACHINE BREAK-IN**

A special break-in procedure has been developed to ensure the integrity of the seed tender when first put into service. Follow the Before Starting instructions and then follow the Inspections for 1/2, 5, and 10 hour instructions at the appropriate interval.

After completing these instructions, follow the normal service schedule in the Maintenance and Service sections and the engine manual.

#### **3.3.1 Before Starting:**

1. Read and follow the instructions in this manual, and the engine manual.
2. Review and follow the Pre-Operation Checklist before starting machine.
3. Initially check wheel bolt torque and then again at 10, 25, and 50 miles.  
Refer to Section 7.4 Bolt Torque.
4. Start the engine and check the controls. Be sure that they function properly.

#### **3.3.2 Inspections at 1/2, 5, and 10 Hours:**

1. Check the engine.
  - Fill fluids as required.
2. Check the bolted connection between the hydraulic motor and auger.
3. Check hardware and fasteners; frame to trailer tie-downs, all fasteners, and wheel bolts. Tighten to their specified torque.
4. At 10 hours, change the engine oil.
  - Check engine manual for the specified oil.

### 3.4 PRE-OPERATION CHECKLIST

Efficient and safe operation of this Meridian® Bulk Seed Tender requires that each operator reads and follows the operating instructions and all related safety precautions identified in this manual.

This pre-operational checklist is provided for both personal safety and to maintain the efficient operation of the tender. Check the following areas each time before you operate this tender:

1. Lubricate the machine, as outlined in the Service and Maintenance section.
2. Check the engine oil and fuel levels.
  - Add, if required.
3. Check the hydraulic oil level in the reservoir.
  - Add, if required.
4. Check the hydraulic motor coupler for wear.
5. Check hardware and fasteners; seed tender frame to trailer tie-downs, hitch bolts, trailer hitch to trailer bolts, and all other fasteners. Tighten to their specified torque.
6. Make sure the wheel bolt lug nuts are tight.
7. Check the tires and ensure that they are inflated to their specified pressure.
8. Remove all entangled material.
9. Visually inspect the auger, auger tube, and delivery spout for damage.
10. Test the Break-Away brake unit and the trailer brakes.
  - d. Make sure the trailer brakes are operating properly.
  - e. Be sure the trip wire to the break-away switch is connected to the tow vehicle.
  - f. Make sure the pin is correctly installed in the break-away switch.
  - g. Press the Test button to see if the indicator illuminates green. If the red light illuminates, the battery charge is low. Refer to the Break-Away System in the Maintenance section for instructions on charging the battery.

**IMPORTANT:**

The engine warranty is void if the engine is run without oil.

### 3.5 ATTACHING TO TOW VEHICLE

#### **⚠ WARNING**

##### UPENDING HAZARD

Do not stand over hitch when unhooking the trailer from the tow vehicle.

Load seed box 1 (closest to hitch) first to keep weight on the hitch.

Unload seed box 2 first to keep weight on the hitch.

#### **⚠ WARNING**

##### CRUSH HAZARD

Ensure that all bystanders, especially small children, are clear of work area.

Ensure there is enough room and clearance to safely back up to the tender.

1. Complete the Pre-operation Checklist.
2. Use the trailer jack to lift the hitch above the height of the receiver on the tow vehicle (standard hitch assembly shown).
3. Remove the retainer pin. Release or open the receiver by pulling the locking cover back, as shown.
4. Slowly back the tow vehicle until the hitch and ball are aligned.
5. Lower the hitch onto the ball.
6. Raise the jack and place it in its stowed position.

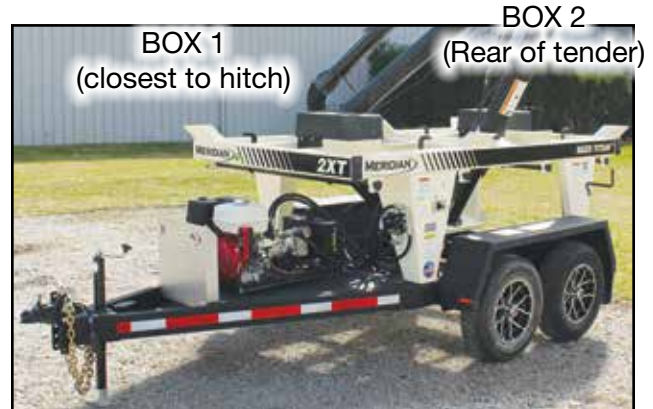

Fig 22 - Box position identification



Fig 23 - Trailer jack and hitch receiver

7. Close the receiver by pulling the spring loaded locking collar back to release the hitch mechanism.
  - Install the retainer clip to prevent unwanted opening of the receiver.
8. Attach the safety chain securely to the tow vehicle to prevent unexpected separation.
  - Cross the chains when attaching.
9. Connect the wiring harness for the lights and brakes.
10. Connect the break-away system cable to the tow vehicle.
  - Plug the key on the end of the cable into the receiving unit.
11. Route all the cables in a manner that will prevent snagging.
  - Be sure to provide slack for turning.



Fig 24 - Break-Away cable

**IMPORTANT:**

Auger tube must be folded down in transport position at all times while towing.  
Must not be towed with auger tube extended in operating position.

**NOTICE****PENDING HAZARD**

Seed tender must be connected to tow vehicle at all times during operation to avoid unit from tipping backwards.

### 3.6 LOADING SEED BOXES

The images in this section identify the correct method for loading and unloading seed boxes from the unit. The tenders shown may not be the exact model described in this manual.

#### NOTICE

##### UPENDING HAZARD

Tender must be connected to tow vehicle at all times during operation to avoid tipping backwards.

#### ⚠ WARNING

##### UPENDING HAZARD

- Always load the front seed box first to maintain a positive tongue weight.
- Negative tongue weight can cause the hitch to rapidly swing upward if not securely fastened to the tow vehicle, which can result in personal injury.

#### ⚠ WARNING

##### CRUSH HAZARD

- Use caution when lifting seed boxes.
- A typical seed box weighs 330 lb (150 kg) when empty.
- Seed boxes have the capacity of holding up to 2500 lb (1135 kg) of seed.
- Keep bystanders away from loading area at least 15 ft (4.5 m) from the seed box.
- Use a lifting device with a rated lift capacity capable of safely moving the seed boxes.

1. Remove the two hairpin retainer clips and remove the hopper covers.
  - Place the clips back into the retainer studs.
  - Store the cover in between the two hoppers.
2. Make sure there are no foreign objects or impacted seed blocking the hopper chute leading to the auger.

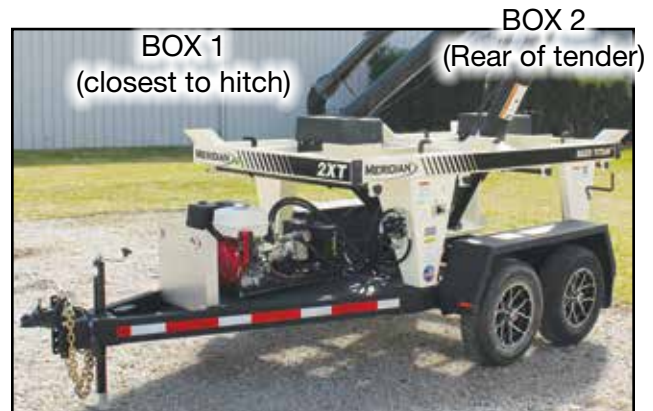

Fig 25 - Box position identification



Fig 26 - Hopper cover



Fig 27 - Hopper cover in storage

3. Clean the frame of debris and stand clear.
4. Rotate the lock-down handles to open the latches, before loading the seed box.

**⚠ CAUTION**

**PINCH POINT**

Keep body parts away from between seed box and frame when loading.

5. Use a suitable lifting device, to carefully place the seed box onto the tender.
6. Make sure the seed box is seated properly over the hopper and rubber boot.
7. Make sure the rubber boot contacts the bottom of the seed box.
8. Rotate the lock-down handles to secure the latches in place to hold down the seed box.

**IMPORTANT:**

Rubber hopper boots must be checked after loading seed boxes to ensure they are sealed all around prior to opening seed box gates.

**IMPORTANT:**

Seed boxes must be locked down at all times while loaded on the unit, empty or full.

9. To remove seed boxes:
  - Work slowly to identify any shifting weight quickly.
  - Start by unloading Box 2 from the rear.
  - Unload Box 1 second.



Fig 28 - Seed box lock-down handles and latches

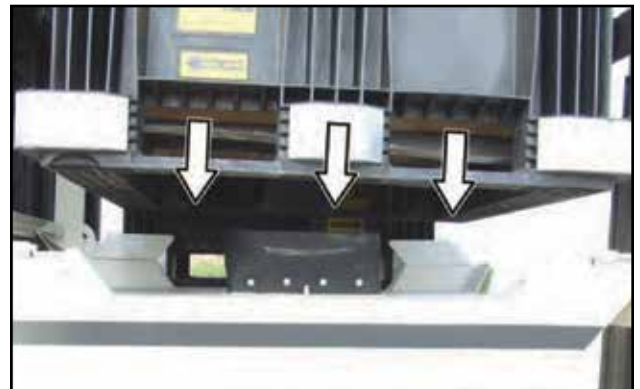

Fig 29 - Lower seed box onto hopper

### 3.7 DELIVERING SEED TO PLANTER

1. Position the seed tender near the planter.
2. Shut off the engine of the tow vehicle, set the parking brake, and remove the ignition key before leaving the cab.

#### IMPORTANT:

Seed tender must be connected to tow vehicle at all times during operation to avoid unit from tipping backwards.

#### DANGER

##### ELECTROCUTION HAZARD

Keep away from power lines.

- Be aware of your surroundings when raising or lowering the auger tube.
- Maintain at least 20 feet between the equipment and any electrical hazard.
- Contact with electricity can result in serious personal injury or death.

#### WARNING

##### CRUSH HAZARD

Do not move the upper auger tube while the seed box(s) are unlatched.



Fig 30 - Auger tube in transport position



Fig 31 - Gas engine

3. Start the gas engine.
  - a. Move fuel valve lever to the ON position.
  - b. To start a cold engine, move choke lever to the CLOSED position.
  - c. Turn the key switch to the START position. Release the key switch when the engine ignites.
4. Allow the engine to warm up for two or three minutes. If the choke was closed to start the engine, gradually open it as the engine warms up.

## NOTICE

### AUGER DAMAGE HAZARD

- Be sure auger cable is threaded into the hole in the end of the upper auger.
  - Damage to the auger can occur if the cable is not properly inserted.
  - Watch out that the cable is not bent while unfolding the tube.
  - If the cable becomes bent or damaged, the auger cannot engage the two halves.
5. Use the hydraulic valve on the side of the tender to operate the tube unfolding cylinder.
    - Unfold tube to sit directly on lower tube.
  6. Lock the tube together with the over-center latch clamp.
  7. Unhook the delivery spout.
    - Remove the hairpin retainer clip which locks the hook in place.
  8. **IMPORTANT:** For best performance, set the hydraulic flow control valve to 6-7.
    - Further adjustment may be necessary depending on product type and condition.
  9. Increasing the engine speed to maximum.



Fig 32 - Auger drive coupling



Fig 33 - Hydraulic valve



Fig 34 - Tube clamp and delivery spout

## **⚠ WARNING**

### UPENDING HAZARD

- Always unload seed box 2 first to maintain a positive tongue weight.
- Negative tongue weight can cause the hitch to rapidly swing upward if not securely fastened to the tow vehicle, which can result in personal injury.

10. Open the seed box slide gate.
11. Fill the planting equipment.
  - a. Move the delivery spout to the bin and start the auger.
  - b. When the bin is full, stop the auger and move to the next one.
  - c. Repeat this process until planter is full.
12. When the job is done, close the seed box slide gate.
13. Then, switch off the auger.

### **IMPORTANT:**

If the tender will not be used again for an extended period of time, the auger tube should be cleared of all seed. This will help prevent the tube from being clogged with seed.

14. Turn off the gas engine.
  - Close the Fuel Shut-Off valve.
  - **IMPORTANT:** Fuel Shut-Off valve must be closed before towing the seed tender on the open road.

## **⚠ DANGER**

### ELECTROCUTION HAZARD

- Keep away from power lines.
- Auger tube must be folded down in transport position while towing.
- **DO NOT** tow tender with auger tube upright in operating position.



Fig 35 - Auger tube and delivery spout



Fig 36 - Auger tube in transport position

15. Hook the delivery spout to the tube for storage.
16. Use the hydraulic valve to fold the auger tube into transport position, if the tender is going to be moved.

### 3.8 UNPLUGGING

#### **WARNING**

**ENTANGLEMENT HAZARD**  
Do not place hands or fingers  
near rotating or moving parts.

#### **IMPORTANT:**

Do not operate the auger when it is  
plugged with excess seed or is hindered  
from moving by a foreign object.  
Continued operation can cause damage.

If the auger tube plugs, follow these  
instructions:

1. Stop the engine and remove the ignition  
key.  
- Lock-Out, Tag-Out the tender system.
2. Open the top and/or bottom access door(s)  
between hopper chutes.
3. Clean out seed and remove any  
obstruction.
4. Close and secure the access door(s).



Fig 37 - Top clean-out access door



Fig 38 - Bottom clean-out access door

## 3.9 STORAGE

### SAFETY INSTRUCTIONS

#### PERSONAL INJURY HAZARD

- Store the tender in an area away from human activity.
- Do not permit children to play on or around the stored machine.
- Store the unit in a dry, level area. Support the frame with planks, if required.

#### 3.9.1 Placing into Storage:

After the season's use or when it will not be used for an extended period of time, the tender should be inspected and prepared for storage.

Repair or replace any worn or damaged components to prevent unnecessary downtime at the beginning of the next season.

To have a long, trouble-free life, follow these instructions:

1. Remove all seed from the hopper chutes and inside the auger tube.
2. Inspect all moving or rotating parts and remove any entangled material.
3. Thoroughly wash the tender to remove all dirt, mud, debris and residue.
  - Wash around and inside the hoppers and their chutes.
  - Clean inside the auger tube.
4. Lubricate all grease fittings and bearings. Refer to Section 4.2

Make sure that all grease cavities have been filled with grease to remove any water residue from the washing. This also protects the bearing seals.

5. Inspect, clean, and lubricate the auger tube hinge.

6. Inspect the condition of the auger flighting and delivery spout. Replace or adjust, as required.
7. Touch up paint nicks and scratches to prevent rusting.
8. Remove the ignition key and store in a secure place.
9. Remove the battery.
  - Be sure it is fully charge, check monthly.
  - Store it inside.
  - Do not sit battery on a cold, concrete floor.
10. Store the machine inside if possible.
  - If it must be outside, cover with a waterproof tarp and tie down securely.

#### 3.9.2 Removing From Storage:

When removing the tender from storage, in preparation for work:

11. Remove the tarp, if covered.
12. Install and connect the battery.
13. Review and follow the Pre-Operation Checklist.
14. Review and follow the Service Intervals in the Maintenance section.

#### IMPORTANT:

If the machine has been stored for more than twelve months, warm the engine by running it for two to three minutes. Then drain the oil. Change the oil while the oil is warm to remove any condensation.

## Section 4: SERVICE AND MAINTENANCE

### WARNING

- Review the Operator's Manual and all safety items before maintaining the tender.
- Follow good shop practices:
  - Keep service area clean and dry.
  - Be sure electrical outlets and tools are properly grounded.
  - Use adequate light for the job at hand.
- Lock-Out, Tag-Out tender operation.
- Clear the area of bystanders, especially children, before repairing or adjusting.
- Keep hands, feet, hair and clothing away from all moving and/or rotating parts.
- Before servicing, repairing or unplugging; stop engine, remove ignition key and wait for moving parts to stop.
- Ensure there is plenty of ventilation.
  - Never operate engine in a closed building.
  - Exhaust fumes may cause asphyxiation.
- Place stands or blocks under frame before working beneath the unit.
- When maintenance is complete, before resuming work, install and secure all guards.
- Keep safety decals clean. Replace any decal that is damaged or not readable.

By following the operating instructions, in conjunction with a good maintenance program, your tender will provide many years of trouble free service.

Original Equipment Manufacturer (OEM) literature, for components of this tender, are stored in the document holder, attached to the tender frame. For more specific information contact the manufacturer directly.

### 4.1 FLUIDS AND LUBRICANTS

#### **Fuel and Engine Oil:**

Refer to the engine manual for specific information:

- Crankcase capacity
- Type of fuel to use, and quantity

#### **Storing Lubricants:**

Your machine can operate at top efficiency only if clean lubricants are used. Use clean containers to handle all lubricants.

Store them in an area protected from dust, moisture and other contaminants.

#### 4.1.1 Greasing:

Use an SAE multipurpose high temperature grease with extreme pressure (EP) performance. Also acceptable, SAE multipurpose lithium based grease.

### NOTICE

#### GREASING HAZARD

- Too much grease causes excessive overheating.
- Under-greasing accelerates equipment wear.
- No grease should be seen around bearings. If there is, too much grease was applied and the seal has ruptured!

#### IMPORTANT:

- Grease bearings only one pump per month under normal usage conditions.
- Bearing greasing frequency should be determined by usage and conditions.



Fig 39 - Seed Titan

1. Use a hand-held grease gun for all greasing.
2. Wipe grease fitting with a clean cloth before greasing, to avoid injecting dirt and grit.
3. All bearings are greasable, but require only minimal grease.

Recommended greasing is one small stroke every month. Be careful not to over-grease as this may push the seal out.

4. Replace and repair broken fittings immediately.
5. If fittings will not take grease, remove and clean thoroughly. Also clean lubricant passageway. Replace fitting if necessary.

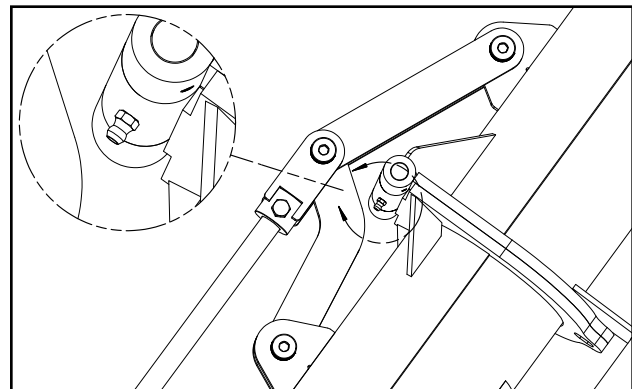

Fig 40 - Grease zerk on tube folder-over hinge

## 4.2 SERVICING INTERVALS

The following recommended periods are based on normal operating conditions. Severe or unusual conditions may require more frequent lubrication and oil changes.

Schedules may vary depending on options and engine model contained in your equipment.

### **WARNING**

#### FIRE HAZARD

- Gasoline is a highly combustible fuel.
- Improper use, handling, or storage of gasoline can be dangerous.
- Never touch or fill a hot engine.
- DO NOT fill fuel tank near an open flame, while smoking or while engine is running.
- DO NOT fill tank in an enclosed area with poor ventilation.
- Wipe up spills immediately.

#### **IMPORTANT:**

For engine servicing and maintenance, refer to its manual for complete details.

The axle is built by Dexter Axle Company. Refer to their online maintenance information.

#### **4.2.1 After 10 Hours or Daily:**

1. Check engine oil level
  - Fill as needed.
2. Check engine fuel level.
  - Add as needed.
3. Check hydraulic oil level in reservoir.
  - Add as required.
4. Test trailer break-away system.
5. Check wheel bolt torque at 10, 25, and 50 miles.

#### **4.2.2 After 50 Hours or Weekly:**

6. Clean or replace the engine air filter element.
  - Clean or replace the foam filter.
  - Replace the paper air filter, as required.
7. Check the tire pressure. Inflate tires to the recommended pressure stated on the tire.
8. Inspect the coupler in the hydraulic motor for wear.
9. Oil hydraulic drive coupler or chain.

#### **4.2.3 After 100 Hours or Monthly:**

10. Grease the tube fold-over hinge.
11. Check torque on wheel nuts.
12. Adjust the trailer brakes.
13. Inspect tires for wear.
14. Grease the axles.
15. Inspect brake magnets for wear.
16. Inspect suspension parts for wear.

**4.2.4 After 200 Hours or Annually:**

17. Change engine oil.
18. Change the hydraulic filter.
19. Check the hydraulic oil.
  - Change the oil if necessary.
20. Check that the battery retains its maximum charge.
21. Check wheel bolt torque.
22. Inspect brake lining wear,
  - Check brake cylinder for leaks
  - Inspect brake wiring for damage.
23. Repack the wheel bearings
  - Check for excessive play in the bearings.
  - Grease the wheel bearings
24. Check the wheel hubs for wear.
25. Inspect grease seal for leakage.
26. Inspect springs for any wear or loss of arch.
27. Inspect all electrical wiring connections for looseness or corrosion.
  - Tighten and/or seal, as necessary.
28. Check frame and trailer hold-down bolts.
29. Check the tires for wear. Replace if needed.
30. Thoroughly clean the tender.



Fig 41 - Tender wheels

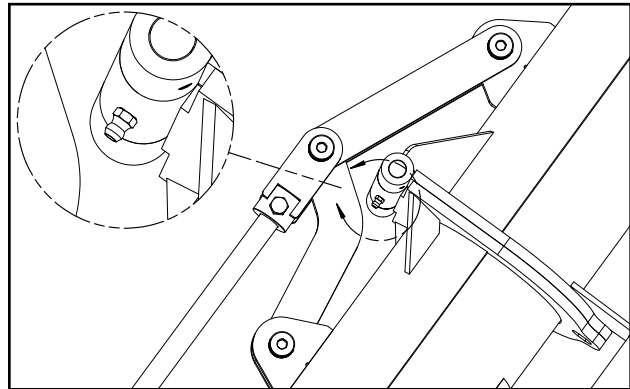

Fig 42 - Grease zerk on tube folder-over hinge

## 4.3 MAINTENANCE PROCEDURES

### 4.3.1 Tires:

Check the tires for normal and/or abnormal tire wear. Replace tires that are damaged or worn beyond normal tread life.

Replace the tires with Meridian® part number 14209 or an equivalent tire:

ST205/75 R14

TR643

Load Range C

For Trailer Service Only

### 4.3.2 Wheel Bearings:

Each axle is equipped with a grease zerk under the center dust cap of the wheel. Add grease sparingly to the wheel bearings, using only wheel bearing grease. The wheel bearings should be repacked annually. Check for excessive end play and tighten, if necessary.

#### **IMPORTANT:**

Over greasing wheel bearings can cause them to overheat, resulting in damage and/or failure.

### 4.3.3 Tube Fold-Over Hinge:

Add grease to the pivot shaft hinge until it is forced out of the joints annually or as needed.

### 4.3.4 Welding Repairs:

Repair welding must be done with care and with procedures that may be beyond the capabilities of the ordinary welder.

Before performing any type of welding repair to the tender, contact Meridian® for approval.

#### **IMPORTANT:**

Anyone performing a welding repair should be certified in accordance to the American Welding Society (AWS) standards.

### 4.3.5 Battery:

## SAFETY INSTRUCTIONS

### BATTERY HAZARD

- Keep all sparks and flames away from batteries, as the gas given off by electrolyte is explosive.
- Avoid contact with battery electrolyte. Wash off any spilled electrolyte immediately to avoid severe chemical burns.
- Wear safety glasses when working near batteries.
- Do not tip batteries more than 45 degrees, to avoid electrolyte loss.
- To avoid injury from spark or short circuit, disconnect the battery ground cable before servicing any part of the electrical system. Never short circuit battery. It may explode.
- Protect battery terminals, battery charger terminals, and cables against accidental contact which can cause sparks, explosions, or component damage.
- Never attempt to jump start a frozen battery.

Inspect the battery at least once every six months and before using the seed tender at the beginning of the season. Always follow the safety instructions when servicing a battery.

**Battery Replacement and Maintenance Tips:**

- Check the batteries at least every six months for low Voltage, leakage, etc.
- Always use the correct size and type of battery. Replace old batteries with a new SP-30 Lawn and Garden battery with 230 CCA and 290 CA ratings.
- Do not install the battery cable to the wrong terminal. Make sure the RED cable is connected to the + (plus) terminal and the BLACK cable is connected to the – (minus) terminal.
- Remove the batteries from the seed tender if not expected to be in use for several months.
- Use recommended practices when recharging a dead battery.
- Remove any corrosion from the battery post using a wire brush terminal cleaner. Corrosion can also be removed using a baking soda paste and water to neutralize and remove the acid from the battery terminals.
- Dispose of old batteries properly.
- Make sure the tie-down strap is connected to the frame of the battery box and in good condition (not cracked, cut, or damaged).
- The battery is not charged when the engine is operating. If the battery is not charging using an external charger, check the fuse. Replace the fuse if necessary.

**4.3.6 Engine:**

Refer to the engine manual for complete details on your particular model.

**SAFETY INSTRUCTIONS****REFUELLING HAZARD**

- Handle fuel with care. It is highly flammable.
- Allow engine to cool for five minutes before refuelling. Clean up spilled fuel before restarting engine.
- Do not refuel the machine while smoking or when near open flame or sparks.
- Fill fuel tank outdoors.
- Prevent fires by keeping machine clean of accumulated trash, straw, grease, and debris.

**Approved Fuel:**

Use unleaded automotive gasoline for all operating conditions.

- Fuel tank capacity is 6.4 US quarts (6.1 liters).

**Engine Oil:**

Use a typical SAE 10W-30 or 10W-40 multiviscosity motor oil for normal operating conditions. Consult your engine manual for the recommended oil in cold temperatures.

- Crankcase capacity is 1.16 US quarts (1.1 L).

### Change Engine Oil:

#### CAUTION

BURN HAZARD  
Hot engine oil can burn skin.

1. Review the engine manual.
2. Allow the engine to cool before changing oil. Draining works best when the oil is warm.
3. Be sure the engine key switch is in the OFF position and the fuel valve is turned OFF.
4. Place a pan under the drain plug. Remove the drain plug and allow the oil to drain for ten minutes.
5. Reinstall the drain plug and tighten.
6. Dispose of the oil in an approved container.
  - Follow industrial disposal regulations.
7. Fill the engine with SAE 10W-30 oil for general usage. If the engine is operated in more extreme conditions, refer to the engine manual for oil recommendations.
8. Run the engine for one minute and recheck the oil level. Add oil, as needed.

### Air Cleaner and Filter:

Check and remove any debris from the foam cover of the air cleaner daily before each use. Thoroughly wash or replace the foam cover every three months or 50 hours of operation (clean it more frequently when used in dusty conditions).

### 4.3.7 Engine Speed Setting:

#### WARNING

ROTATING PART HAZARD  
The engine speed must be adjusted with the engine running. Use extreme caution when working near rotating parts.

Every engine is set with a high idle of 3000 RPM. Before using the seed tender, check the RPM.

1. Start the engine. Set the engine to high idle (full throttle).
2. Use a screwdriver to reset the high idle stop screw if required to obtain the desired speed



Fig 43 - Engine speed setscrew

#### 4.3.8 Change Hydraulic Oil:

1. Stop engine and remove ignition key before maintaining.

### WARNING

#### HOT LIQUID HAZARD

Engine and hydraulics must cool before changing the oil. Hot oil can cause burns if it contacts exposed skin.

#### IMPORTANT:

Annually, have an oil sample tested for particle count.

Change oil only if necessary.

2. Allow the hydraulics to cool slightly before changing oil.

#### Note:

It is best to change oil while the engine is warm (not hot) to keep contaminants in suspension.

3. Place a large pan or pail under the drain plug.
  - Reservoir capacity is 3 US Gal (11.4 Liters).
4. Remove drain plug and allow to drain for ten minutes.
5. Install and tighten the drain plug.
6. Dispose of the used oil in an approved container and manner.
7. Fill the reservoir with specified oil.

#### 4.3.9 Change Hydraulic Oil Filter:

1. Place a pan under filter to catch any spilled oil.
2. Remove hydraulic oil filter, and dispose of it.
3. Fill the new filter with hydraulic oil.
4. Apply a light coat of oil to the O-ring and install the new filter. Snug up by hand and then tighten another 1/2 turn.
5. Run the engine for 1-2 minutes and check for oil leaks.
6. If leaks are found around the drain plug or filter, tighten slightly.
7. Check oil level. Top up as required.



Fig 44 - Hydraulic oil filter

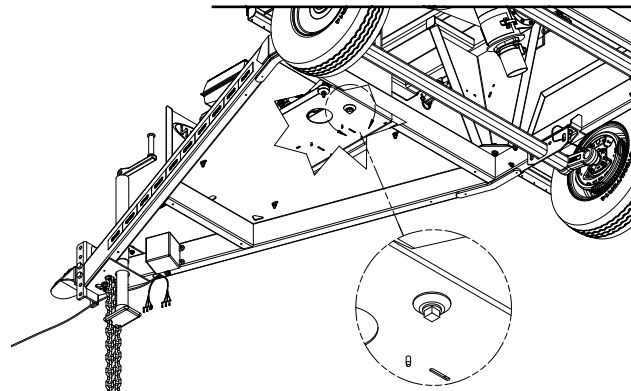

Fig 45 - Hydraulic oil drain plug

#### 4.3.10 Unplugging Auger Tube:

**IMPORTANT:**

Do not operate auger when it is plugged with excess seed or is hindered from moving by a foreign object. Continued operation can cause damage.

If the auger becomes plugged, follow these instructions:

1. Stop the engine and remove the ignition key. Lock-Out, Tag-Out the engine to prevent accidental starting of the tender.
2. Open the top and/or bottom access door(s) and remove any excess seed or obstruction.
3. Close and secure the lower access door.



Fig 46 - Top clean-out access door



Fig 47 - Bottom clean-out access door

### 4.3.11 Trailer Break-Away System:

#### Testing the Battery:

1. Disconnect the trailer plug from the tow vehicle; otherwise, you are testing the tow vehicle's battery.
2. Press the green TEST button on the control box located inside the frame of the trailer.
  - The green indicator light will illuminate if the battery is fully charged.
  - If the yellow or red indicator lights illuminate, the unit's battery should be charged before towing the trailer.



Fig 48 - Break-Away location

#### **IMPORTANT:**

If the battery is weak or dead (red indicator, even after charging), as indicated by the indicator light, the battery must be replaced.

3. Plug the trailer into the tow vehicle. The yellow "Charging" light should be ON.
4. Test the system by pulling the pin out of the break-away switch. The battery will activate the brakes. (**Note:** Do not use this kit as a parking brake). The battery should be charged and tested prior to each trailer outing.



Fig 49 - Break-Away system

#### Changing Battery:

The battery in the break-away system is rechargeable. If the battery will not hold a charge, replace the battery.



Fig 50 - Break-Away pin

#### Replacing Battery:

The battery in the break-away system is replaceable. If the battery will not hold a charge, replace the battery. Contact the OEM supplier for a replacement battery.

#### 4.3.12 Wheel Bolt Torque Requirements:

### WARNING

#### EXPLOSIVE FORCE HAZARD

To prevent injury due to possible dangerous separation of wheels from the axle, the wheel nuts must be maintained at the proper torque levels. Properly tightened wheel nuts prevent loose wheels and broken studs.

Initially check the wheel bolt torque at 10, 25, and 50 miles, as well as after each wheel removal.

#### Note:

Torque wrenches are the best method to ensure the proper amount of torque is being applied to a wheel nut.

1. Tighten the wheel nuts in three stages:
  - First stage: 20 to 25 foot pounds.
  - Second stage: 50 to 60 foot pounds.
  - Third stage: 90 to 120 foot pounds.
2. Tighten the wheel nuts in a clockwise, cross-axle alternating pattern.

#### 4.3.13 Axle Bolts and Frame Hold-Down Bolts:

Check the torque on the axle/frame bolts at least once per year.

Check the torque on the frame hold-down bolts at least once per year.

Refer to Section 7.4 Bolt Torque.



Fig 51 - Tender wheels



Fig 52 - Axle

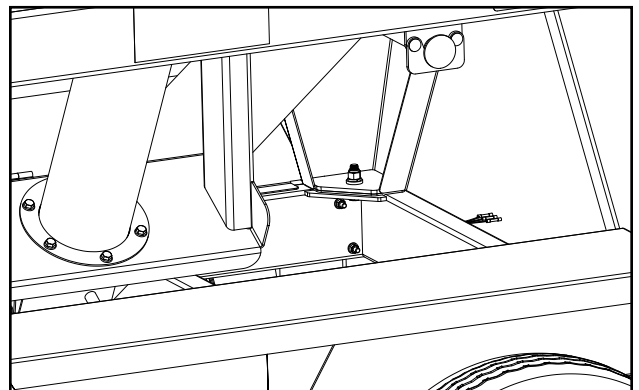

Fig 53 - Frame hold-down bolts

This page intentionally left blank



## 4.5 ORDERING PARTS

Always give the Model Number and Serial Number when ordering parts.

To get your parts promptly the following information will be required:

- The part name and number
- Your Name, Address, Town, Province/State, Country
- Complete information for shipping

Confirm all phoned in orders in writing. If Purchase Orders are required please note the number on the written order.

Unless claims for shortages or errors are made immediately upon receipt of goods, they will not be considered.

Inspect all goods received immediately upon receipt. When damaged goods are received, insist that a full description of the damage is made with the carrier against the freight bill. If this is insisted upon, full damage can be collected from the transport company.

No responsibility is assumed for delay or damage to merchandise while in transit. Dealers responsibility ceases upon delivery or pickup of shipment from or to the transportation company. Any freight damage claims must be made with the transportation company, not with the dealer.

## Section 5: TROUBLESHOOTING

In the following trouble shooting section, we have listed many of the problems, causes and solutions to the problems which you may encounter.

If you encounter a problem that is difficult to solve, even after having read through this trouble shooting section, please contact your authorized dealer, distributor or the factory. Before you call, please have this Operator's Manual and the serial number from your machine ready.

### ***Problem***

<b>Cause</b>	<b>Solution</b>
--------------	-----------------

### *Engine will not start*

No fuel	Fill the fuel tank
Low engine oil	Fill the crankcase with oil
Cold engine	Open choke
Ignition key switch off	Turn ignition key switch on
Battery dead	Recharge or replace battery
Engine problem	Refer to engine manual

### *Auger will not start*

Not rotating	Start engine and increase speed above 1400 RPM
Hydraulic pump couplings or auger motor connection	Repair or replace
Flow control valve	Check flow settings
No hydraulic oil	Check oil level
Hydraulic valve or motor	Ensure hydraulic pump is working properly and hydraulic reservoir is filled with oil.

### *Electrical functions are not working properly*

Battery cable or battery	Check battery cable and make sure battery is fully charged
Improper ground	Check for proper grounding of electrical circuit

### *Remote throttle doesn't work*

No input power	Check charge of battery. Recharge or replace, as required
	Check connections in the remote throttle harness. Be sure connectors are clean and terminals are firmly pushed together.



This page intentionally left blank

## Section 6: REFERENCE

For information not included here, or for a digital copy of this manual, please call your dealer, or Meridian Manufacturing Inc. directly for assistance. Visit our website at: [www.meridianmfg.com](http://www.meridianmfg.com).

**Note:**

The drawings and schematics are contained in a separate parts book.

### 6.1 SPECIFICATIONS

Total Tender Length:	168" (14')
Tender Length:	112" (9' 4")
Tender Height:	37"
Tender Width:	60-1/4"
Tender with Trailer Length:	168" (14')
Tender with Trailer Height:	58"
Tender with Trailer Width:	78-1/2"
Auger Height:	177" (14' 9")
Delivery Height:	168" (14')
Delivery Reach w/o Spout:	60" (5')
Delivery Reach w/Spout Collapsed:	108" (9')
Delivery Reach w/Spout Extended:	204" (17')
Tender Transport Height:	132" (11')
Tender Transport Width:	108" (9')
Tender Deck Height:	51"
Trailer Tire Centers:	69-1/2"

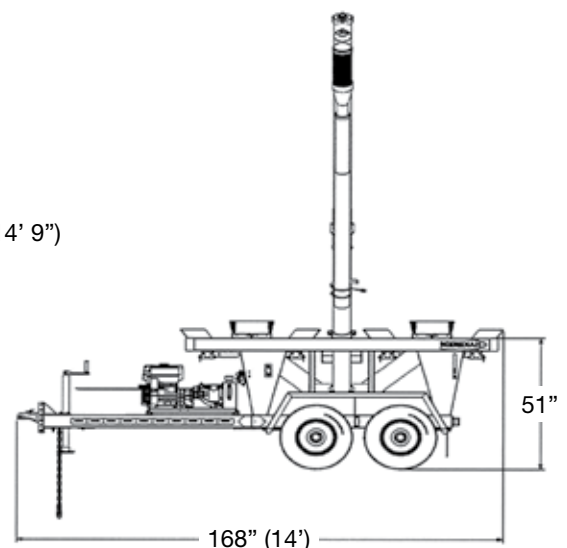
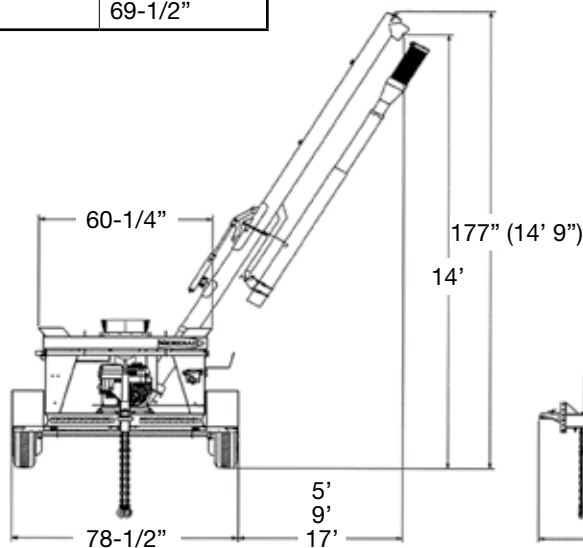
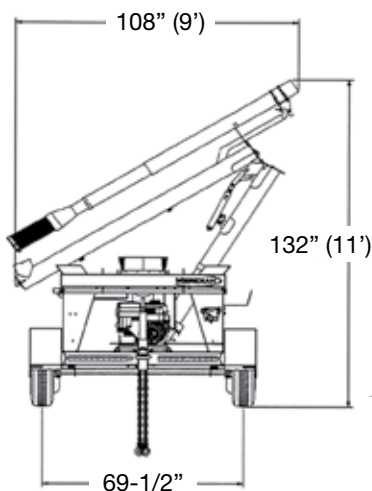
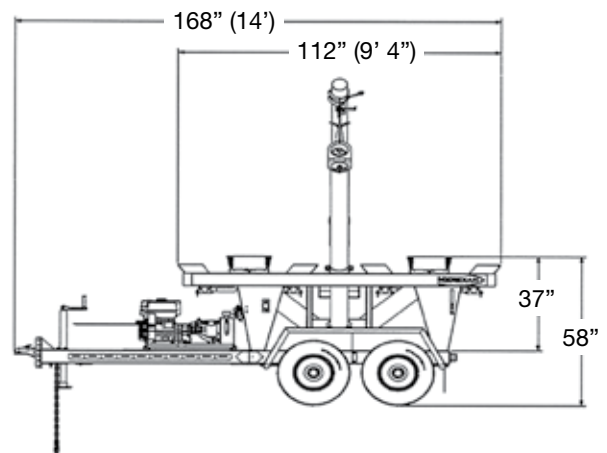

## 6.2 BOLT TORQUE

The tables shown below give correct torque values for various bolts and capscrews. Tighten all bolts to the torques specified in chart unless otherwise noted. Check tightness of bolts periodically, using bolt torque chart as a guide. Replace hardware with the same strength bolt.

IMPERIAL TORQUE SPECIFICATIONS						
Bolt Diameter "A"	Bolt Torque*					
	SAE 2 (Nm) (ft-lb)		SAE 5 (Nm) (ft-lb)		SAE 8 (Nm) (ft-lb)	
	1/4"	8	6	12	9	17
5/16"	13	10	25	19	36	27
3/8"	27	20	45	33	63	45
7/16"	41	30	72	53	100	75
1/2"	61	45	110	80	155	115
9/16"	95	60	155	115	220	165
5/8"	128	95	215	160	305	220
3/4"	225	165	390	290	540	400
7/8"	230	170	570	420	880	650
1"	345	225	850	630	1320	970

Table 1 - Imperial Torque

METRIC TORQUE SPECIFICATIONS				
Bolt Diameter "A"	Bolt Torque*			
	8.8 (Nm) (ft-lb)		10.9 (Nm) (ft-lb)	
	M3	0.5	0.4	1.8
M4	3	2.2	4.5	3.3
M5	6	4	9	7
M6	10	7	15	11
M8	25	18	35	26
M10	50	37	70	52
M12	90	66	125	92
M14	140	103	200	148
M16	225	166	310	229
M20	435	321	610	450
M24	750	553	1050	774
M30	1495	1103	2100	1550
M36	2600	1917	3675	2710

Table 2 - Metric Torque

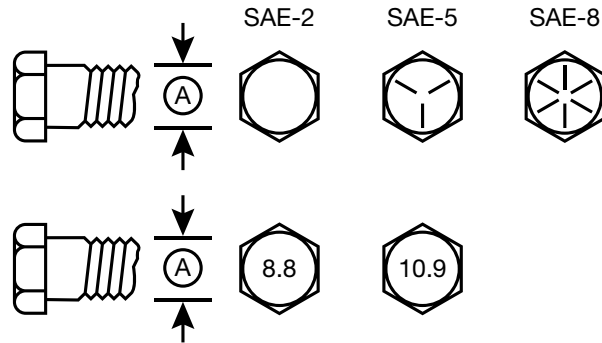

Torque figures indicated above are valid for non-greased or non-oiled threads and heads unless otherwise specified. Therefore, do not grease or oil bolts or capscrews unless otherwise specified in this manual. When using locking elements, increase torque values by 5%.

\* Torque value for bolts and capscrews are identified by their head markings.

# LIMITED MATERIALS AND WORKMANSHIP WARRANTY FOR BULK SEED TENDERS

Meridian Manufacturing Inc. (hereinafter referred to as the Manufacturer) hereby warrants the Fuel Trailer(s) sold by it to be free from any defect in material or workmanship under normal use and service for a period of one (1) year from the date of shipment. The Manufacturer's obligation under this warranty shall be limited to the repair or replacement only, FOB the original point of shipment, of any defective parts or portions of the fuel trailer or accessories manufactured by Meridian®. Any warranty claim must be reported to the Manufacturer within one (1) year from the date of shipment.

## **THIS WARRANTY IS SUBJECT TO THE FOLLOWING LIMITATIONS, PROVISIONS AND CONDITIONS:**

1. This warranty does not apply:
  - a. To any product sold by the Manufacturer where it is used in areas exposed to corrosive or aggressive conditions including salt water, acids, alkaloid, ash, cement dust, animal waste or other corrosive chemicals from either inside or outside the bin.
  - b. For failures or defects arising out of damage during shipment or during storage on site.
  - c. To materials replaced or repaired under this warranty except to the extent of the remainder of the applicable warranty.
  - d. To damage resulting from misuse, negligence, accident or improper site preparation by others.
  - e. If the product has been altered or modified by others.
  - f. If in the case of coating failures the failure is the result of damage, lack of proper maintenance or failure to remove road salt or other contaminants that may have come in contact with the bin surface.
  - g. To loss of time, inconvenience, loss of material, down time or any other consequential damage.
  - h. For a function that is different than original designed intent.
2. The obligation of the Manufacturer under this warranty shall not arise unless the Manufacturer is notified and this warranty is presented together with a written statement specifying the claim or defect within thirty (30) days after the failure is first detected or made known to the owner and within one (1) year from the shipment date. The Manufacturer in its sole discretion shall determine if the claim is valid and whether correction of the defect or failure shall be made by repair or replacement of the materials.
3. The coating warranty is based on the manufacturer's performance specification for Polyester Powder finishes and does not include repair of minor blemishes or rusting that is normally part of the general maintenance of the fuel trailer. This warranty does not cover excessive wear on interior coatings. See attachment for full Performance Specification details on Polyester Powder Finishes.
4. The obligation of the Manufacturer hereunder extends only to the original owner and to the Meridian® dealer to whom the materials may have been initially sold. This warranty shall not be subject to any assignment or transfer without the written consent of the Manufacturer.
5. The customer shall acknowledge that it has made its own independent decision to approve the use of the supplied materials and also the specific fabrication and construction procedures utilized to complete the fuel trailer, and has satisfied itself as to the suitability of these products for this particular application.
6. The foregoing sets forth the only warranties applicable to said materials and said warranties are given expressly and in lieu of all other warranties, expressed or implied, statutory or otherwise, of merchantability or fitness for a particular purpose and all warranties which exceed or differ from said warranties herein are disclaimed by the Manufacturer.
7. The owners sole and exclusive remedy against the Manufacturer shall be limited to the applicable warranty set forth herein and the endorsements, if any, issued together with this document and no other remedy (including but not limited to the recovery of assembly or disassembly costs, shipping costs, direct, incidental, special, indirect or consequential damages for lost profits, lost sales, injury to person or property or any other loss, whether arising from breach of contract, breach of warranty, tort, including negligence, strict liability or otherwise) shall be available to the owner or Meridian® Dealer or any other person or entitles whether by direct action or for contribution or indemnity or otherwise.
8. The financial obligation of the Manufacturer under this warranty shall be limited to the repair or replacement of the product as originally supplied and in no event shall exceed the original cost of the product supplied.
9. The Manufacturer shall not have any obligation under any warranty herein until all accounts for materials, installation and erection of the said product thereof and for labor and other work performed by the Manufacturer or its dealers have been paid in full by the owner.

## **WARRANTY CLAIM PROCEDURE:**

- Registering product with Meridian Manufacturing Inc.
- Contact the dealer unit was purchased from upon discovery of any defects.
- A completed warranty claim form submitted by dealer to Meridian warranty representative for review and course of action.
- Warranty repair work will only be performed by Meridian, the dealer or an approved representative. No warranty work completed prior to approval. Failure to follow procedure may affect any or all reimbursement.
- Claims will be adjudicated at the sole discretion of the manufacturer and in accordance with the terms and conditions of the applicable limited warranty.
- A complete list of warranty procedures can be procured from the Warranty Department or found in your operator's manual.



(800) 437-2334 | [www.meridianmfg.com](http://www.meridianmfg.com) | [tenders@meridianmfg.com](mailto:tenders@meridianmfg.com)